

# Tipaloy TDP PINS FOR USE WITH TCN HEADS (METRIC THREADS)

Tipaloy TDP pins are manufactured from a special alloy steel. Once they are machined to a finish size, they are heat treated through a special process which creates an electrical insulating surface as part of the steel. The hardened surface of the pin electrically insulates the pin and provides a very hard wear surface. Tipaloy manufactures the standard TDP coated pin in standard sizes and a wide range of specials. The product is weld heat resistant and wear resistant due to its hardness. Tipaloy also makes TDP components in forms of sleeves and parts for resistance welding fixtures.

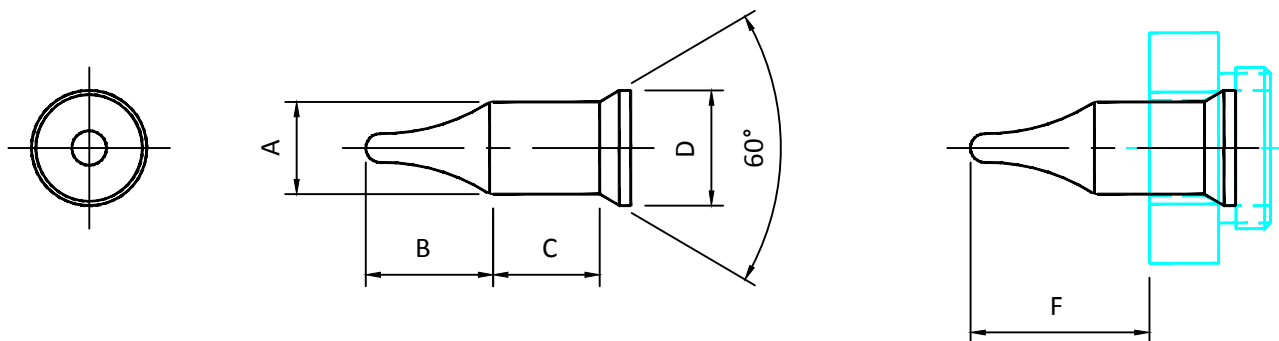

Part Number	A Body Dia.	B Nose Length	C Body Length	D Dia.	E Stickout from Cap
TDP-M04	.188 (5mm)	.24 (6mm)	.59 (15mm)	.472 (12mm)	.48 (12mm)
TDP-M05	.228 (6mm)	.32 (8mm)	.59 (15mm)	.472 (12mm)	.56 (14mm)
TDP-M06	.268 (7mm)	.40 (10.3mm)	.59 (15mm)	.472 (12mm)	.64 (16mm)
TDP-M07	.307 (8mm)	1.00 (25mm)	.59 (15mm)	.472 (12mm)	.68 (17mm)
TDP-M08	.346 (9mm)	1.00 (25mm)	.59 (15mm)	.472 (12mm)	.70 (18mm)
TDP-M09	.386 (10mm)	1.00 (25mm)	.59 (15mm)	.472 (12mm)	.70 (18mm)
TDP-M10	.425 (11mm)	1.25 (32mm)	.59 (15mm)	.630 (16mm)	.75 (19mm)
TDP-M11	.465 (12mm)	1.00 (25mm)	.59 (15mm)	.630 (16mm)	.81 (20mm)
TDP-M12	.504 (13mm)	1.00 (25mm)	.59 (15mm)	.630 (16mm)	.87 (22mm)
TDP-M13	.543 (14mm)	1.00 (25mm)	.59 (15mm)	.630 (16mm)	.87 (22mm)
TDP-M14	.583 (15mm)	1.00 (25mm)	.59 (15mm)	.827 (21mm)	.92 (23mm)
TDP-M15	.622 (16mm)	1.00 (25mm)	.59 (15mm)	.827 (21mm)	.92 (23mm)
TDP-M16	.661 (17mm)	1.00 (25mm)	.59 (15mm)	.827 (21mm)	.95 (24mm)
TDP-M016.5	.642 (16.5mm)	1.00 (25mm)	.59 (15mm)	.827 (21mm)	.95 (24mm)